

Logix 764

Operation Manual

Models: 255

Twin Alternating

Twin Parallel

Single with Remote

Regeneration Start

Multi-Single Tank with

Lockout

Table of Contents

Safety Information	3
How To Use This Manual	4
Location Selection	9
Outdoor Locations	7
Installation	9
Location Selection	9
Water Line Connection	9
Drain Line Connection	9
Brine Line Connection	10
Brine Tank Overflow Line Connection	10
Electrical Connection	11
Disinfection of Water Conditioning Systems	12
System Operation	13
Cycle Water Flows	13
Camshaft Cycle Positions	14
764 Control Operation	14
Display Icons & Cursors	15
Keypad — Buttons	16
Placing Water Conditioning System Into Operation	17
Level I Programming - 764 Control with 255 Valve, 8 Cycle Conditioner	19
Quick Cycling the Control 255L and 255P	20
Quick Cycling the Control for 255A Systems	21
To Place the 255 Alternating System into Operation:	21
In Service Display	23
Programming Overview	23
Level II Programming – P Values	24
Programming the Lockout Feature	25
Level III Cycle Programming – C Values	27
Level IV Viewing History - H Values	28
Program Reset	29
Manual Regeneration Options	30
Regeneration Modes for Parallel Systems	31
Wiring Diagrams	32
Parts Lists	34
255 Exploded View & Parts List	34
Bypass Valve and Turbine Adapter	36
Manifold Kits	37
Troubleshooting	38

Safety Information

This water conditioner's control valve conforms to UL/CE Standards. Generic valves were tested and certified for compliance as verified by the agency listing.

- Please review the entire Installation and Operation Manual before installing the water conditioning system.
- As with all plumbing projects, it is recommended that a trained professional water treatment dealer install the water conditioning system. Please follow all local plumbing codes for installing this water conditioning system.
- This system will not make microbiologically unsafe water safe. Water that is unsafe must be treated separately from this conditioner.
- This water conditioning system is to be used only for potable water.
- Inspect the water conditioning system for carrier shortage or shipping damage before beginning installation.
- Use only lead-free solder and flux, as required by federal and state codes, when installing soldered copper plumbing.
- Use caution when installing soldered metal piping near the water conditioning system. Heat can adversely affect the plastic control valve and bypass valve.
- All plastic connections should be hand tightened. Teflon¹ tape may be used on connections that do not use an O-ring seal. Do not use pipe dope type sealants on the valve body. **Do not use pliers or pipe wrenches.**
- Do not use petroleum-based lubricants such as Vaseline, oils or hydrocarbon-based lubricants. Use only 100% silicone lubricants.
- Use only the power transformer supplied with this water conditioning system.
- All electrical connections must be completed according to local codes.
- The power outlet must be grounded
- Install an appropriate grounding strap across the inlet and outlet piping of the water conditioning system to ensure that a proper ground is maintained.
- To disconnect power, unplug the AC adapter from its power source.
- Observe drain line requirements.
- Do not support the weight of the system on the control valve fittings, plumbing, or the bypass.
- Do not allow this water conditioning system to freeze. Damage from freezing will void this water conditioning system's warranty.
- Operating ambient temperature: 34° to 120°F (1° to 49°C).
- Operating water temperature: 34° to 100°F (1° to 38°C).
- Operating water pressure range : 20 to 120 psi (1.38 to 8.27 bar). In Canada the acceptable operating water pressure range is 20 to 100 psi (1.38 to 6.89 bar).
- Observe all warnings that appear in this manual.
- Keep the media tank in the upright position. Do not turn upside down or drop. Turning the tank upside down or laying the tank on its side can cause media to enter the valve.
- Use only regenerants designed for water conditioning. Do not use ice melting salt, block salt or rock salt.

1. Teflon is a trademark of E. I. duPont de Nemours.

How To Use This Manual

This installation manual is designed to guide the installer through the process of installing and starting water conditioning systems featuring the Logix 764 controller.

This manual is a reference and will not include every system installation situation. The person installing this equipment should have:

- Training in the 764 series control and the 255 valve.
- Knowledge of water conditioning and how to determine proper control settings.
- Adequate plumbing skills.

Icons That Appear In This Manual



WARNING: Failure to follow this instruction can result in personal injury or damage to the equipment.

Note: Helpful hint to simplify procedure.

The Logix 764 control can be installed on several type valves that can have twin alternating, twin parallel or single tank configuration. The section on Logix 764 start-up provides a simple explanation of the valve types that are pre-programmed in the 764 control.

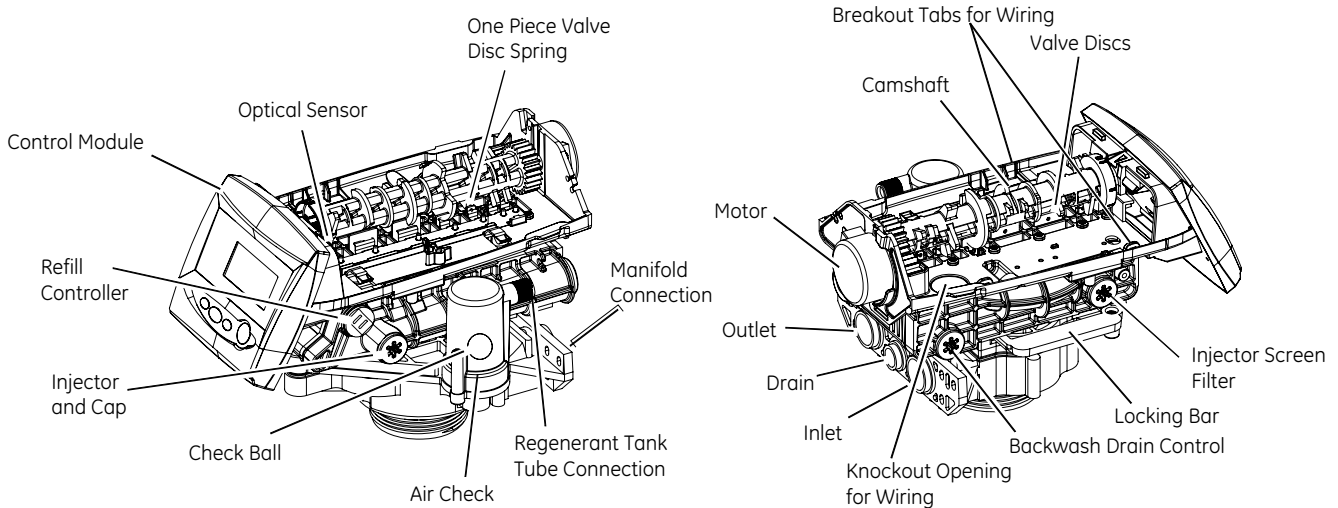

Figure 1 255 Valve Layout

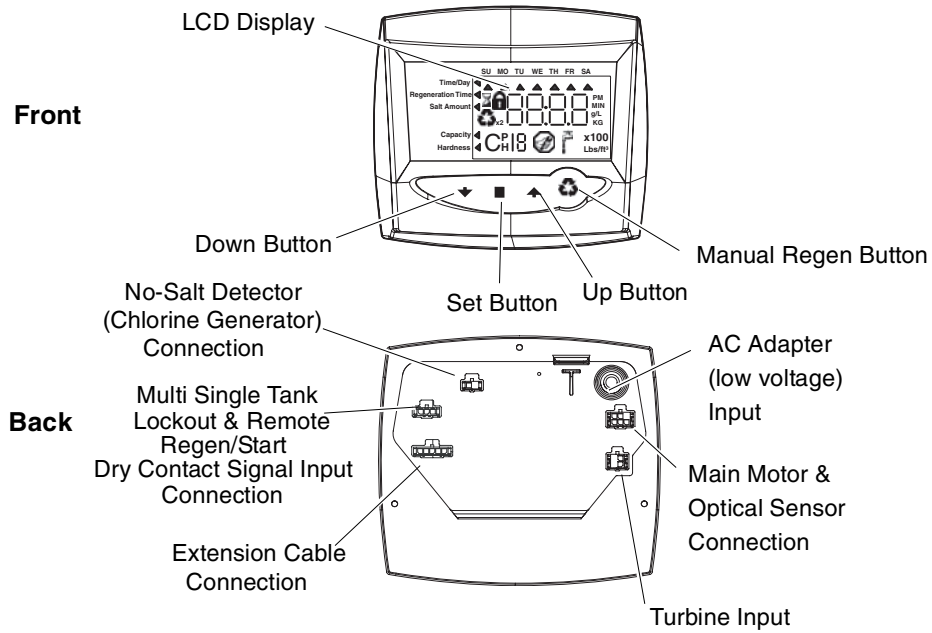

Figure 2 764 Controller Identification

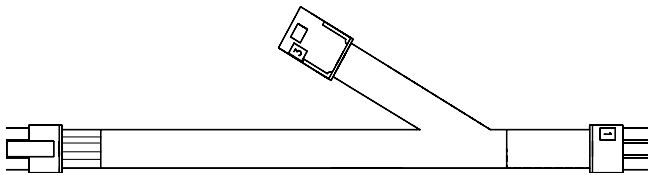

Figure 3 Remote Start/Multi-Tank Lockout Cable

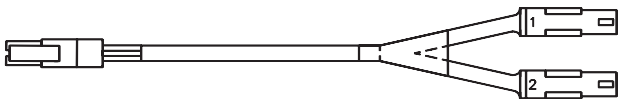

Figure 4 Twin Sensor Cable

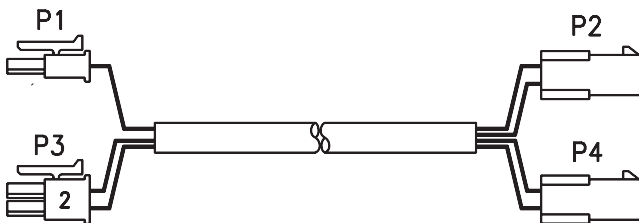

Figure 5 Twin Cable Extension

Location Selection

Location of a water conditioning system is important. The following conditions are required:

- Level platform or floor.
- Room to access equipment for maintenance and adding regenerant (salt) to tank.
- Ambient temperatures over 34°F (1°C) and below 120°F (49°C).
- Water pressure below 120 psi (8.27 bar) and above 25 psi (1.7 bar).
- In Canada the water pressure must be below 100 psi (6.89 bar).
- Constant electrical supply to operate the controller.
- Total minimum pipe run to water heater of ten feet (three meters) to prevent backup of hot water into system.
- Local drain for discharge as close as possible.
- Water line connections with shutoff or bypass valves.
- Must meet any local and state codes for site of installation.
- Valve is designed for minor plumbing misalignments. Do not support weight of system on the plumbing.
- Be sure all soldered pipes are fully cooled before attaching plastic valve to the plumbing.

Outdoor Locations

When the water conditioning system is installed outdoors, several items must be considered.

- Moisture – The valve and control are designed for use in NEMA 3 locations. Falling water should not affect performance. The system is not designed to withstand extreme humidity or water spray from below. Examples are: constant heavy mist, near corrosive environment, or upwards spray from sprinkler.

Caution: This unit is for dry location use only unless used with a Listed Class 2 power supply suitable for outdoor use.

- Direct Sunlight – The materials used will fade or discolor over time in direct sunlight. The integrity of the materials will not degrade to cause system failures. If it is necessary to locate the conditioner in direct sunlight, an outdoor cover (PN 1267811) over the valve and control is necessary. Valve skirts (PN 1267808) are available if further protection is required.
- Temperature – Extreme hot or cold temperatures will cause damage to the valve or control. Freezing temperatures will freeze the water in the valve. This will cause physical damage to the internal parts as well as the plumbing and conditioning resin. High temperatures will affect the control. The display may become unreadable but the control should continue to function. When the temperature returns to normal operating limits the display will re-appear. A protective cover should assist with high temperature applications.
- Insects – The control and valve have been designed to keep all but the smallest insects out of the critical areas. Any holes in the top plate can be covered with duct tape. The top cover should be installed securely in place.
- Wind – The cover, when properly installed on the valve, is designed to withstand a 30 mph (48 Kph).

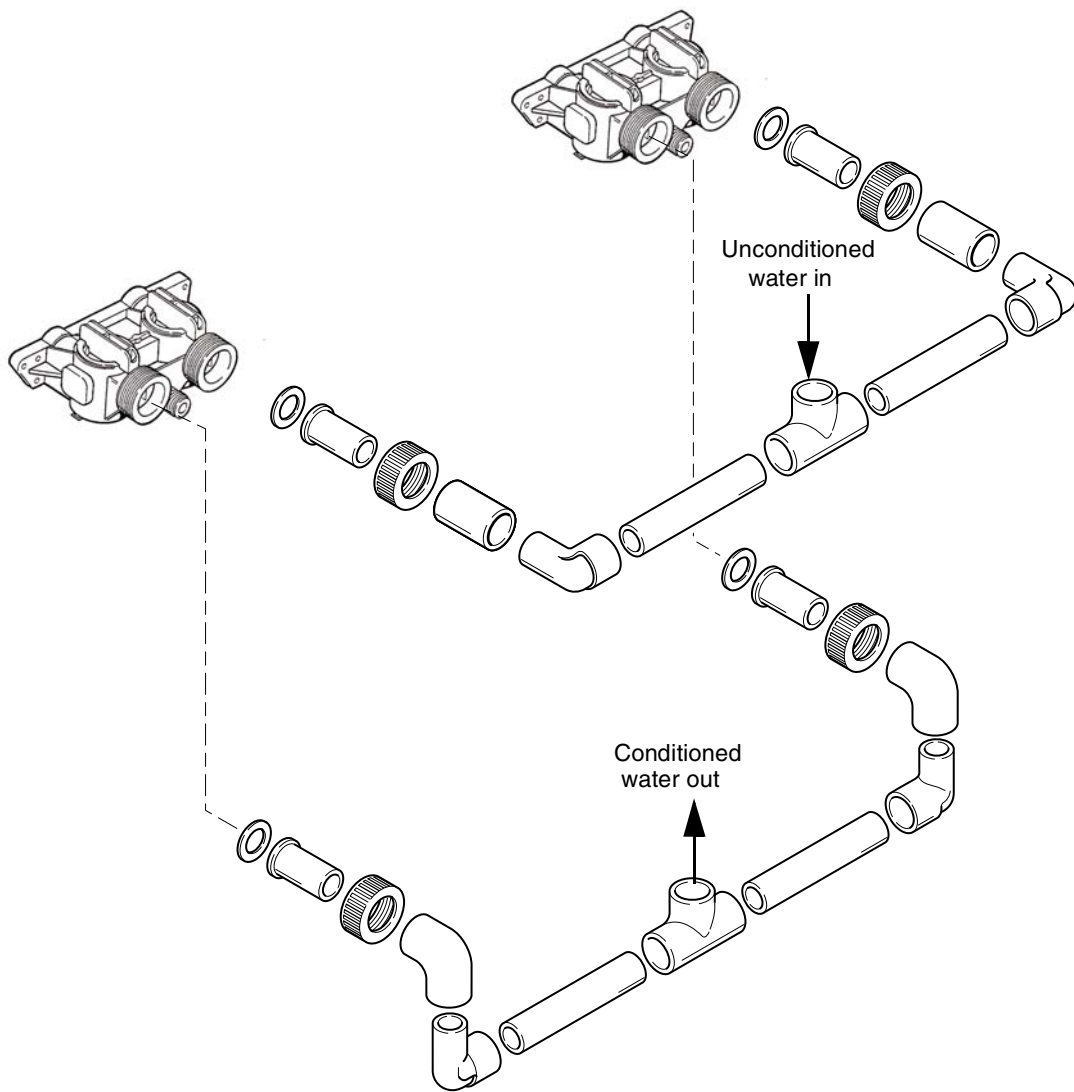

Figure 6 Typical Plumbing for Twin Tank Systems.

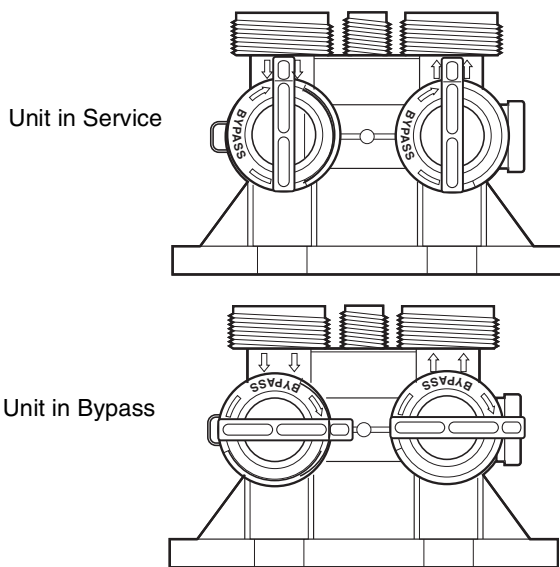

Figure 7

Installation

All plumbing must conform to local codes. The two tanks should be plumbed to an interconnecting manifold, Figure-6. **It is highly recommended that separate brine lines be used for each tank.** It is critical for the resin, resin volume, inlet piping, etc. to be identical for both tanks.



WARNING: Do not use tools to tighten plastic fittings. Over time, stress may break the connections. Hand tighten the nuts.



WARNING: Do not use petroleum grease on gaskets when connecting bypass plumbing. Use only 100% silicone grease products when installing any Pentair Water brand valve. Non-silicone grease may cause plastic components to fail over time.



WARNING: The inlet water must be connected to the inlet port of the valve. When replacing valves, the inlet and outlet may be reversed. Ensure that the plumbing is not installed in the opposite order. Tank media may be pushed into the valve.



WARNING: Filter media may need to be properly conditioned before the filter is placed into full operation. Consult the original equipment manufacturer for proper procedure.

Location Selection

- The following considerations must be taken into account when selecting the location for the water conditioning system.
- Locate the system as close to a drain as possible.
- If supplementary water treating equipment is required, make sure that adequate additional space is available. Locate the brine tank in an accessible place so that salt can be easily added.
- Do not install any system with less than 10 feet (3 m) of piping between the outlet of the conditioners and the inlet of the water heater. Water heaters can transfer heat down the cold water pipe into the control valve. Hot water can severely damage the conditioners.

A ten-foot (3-m) total pipe run (including bends, elbows, etc.) is a reasonable distance to prevent hot water damage. A positive way to prevent hot water from

flowing from a heat source to the conditioners is to install an expandable accumulator tank before the hot water heater. **Always conform to local codes.**

- Do not locate the unit in an area where the ambient temperature is ever below 34°F (1°C) or over 120°F (49°C).
- Maximum allowable water temperature is 100°F (38°C).
- Do not install the unit near acid or acid fumes.
- Do not expose the unit to petroleum products.

Water Line Connection

A bypass valve system must be installed to accommodate occasions when the water conditioning system must be bypassed for supplying hard water or servicing. See Figures 7 and 8.

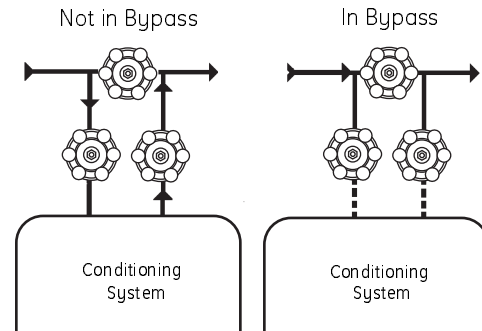

Figure 8

Drain Line Connection

Note: Standard commercial practices are expressed here. Local codes may require changes to the following suggestions. Check with local authorities before installing a water conditioning system.

The system should be above, and not more than 20 feet (6.1 m) from a drain. Connect an appropriate fitting and 1/2-inch (1.3-cm) plastic tubing to the drain line connection on the rear of the control valve.

If the backwash flow is more than 5 gpm or if the unit is located more than 20 feet (6.1 m) from the drain, use 3/4-inch (1.9-cm) tubing for runs up to 40 feet (12.2 m). Also, purchase appropriate fitting to connect the 3/4-inch tubing to the 1/2-inch NPT drain connection.

If unit is located where the drain line must be elevated, you may elevate the line up to 5 feet (1.5 m) providing the run does **not** exceed 15 feet (4.6 m) and water pressure at the conditioners is not less than 40 psi (2.8 bar).

Where drain line is elevated but empties into a drain below the level of the control valve, form a 7-inch (18-cm) loop at the far end of the line so that the bottom

of the loop is level with the drain line connection. This will provide an adequate siphon trap. Where a drain empties into an overhead sewer line, a sink-type trap must be used. Secure the end of the drain line to prevent it from moving (Figure-11).

Brine Line Connection

It is recommended that separate brine lines be used for each tank.

A regenerant tank aircheck is not required when using a 255 valve with the built-in aircheck. Doing so will cause premature checking and may result in hard water or regenerant tank overflow. The 255 aircheck is available standard with a 1/4" NPT tube compression fitting. The use of Teflon tape is required on the 1/4" NPT connection.

Install an appropriate fitting onto the 1/4-inch male NPT connection on the air check (Figure-9), and install a length of 3/8-inch polyethylene tubing between the air check fitting and the brine pick-up tube at the brine tank. If you are using a brine valve remove the ball in the air check to avoid possible premature checking.

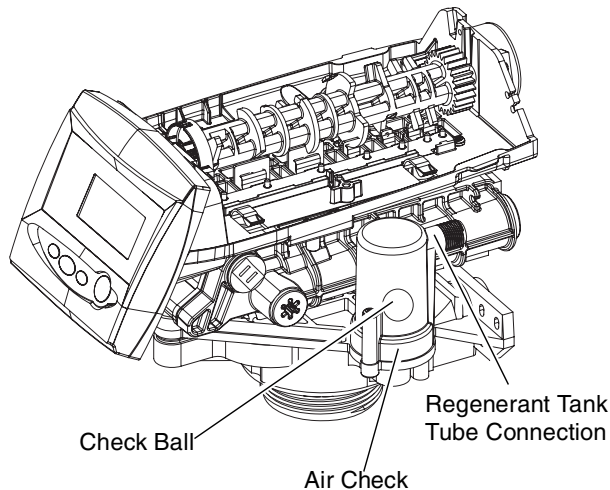

Figure 9

Note: Make sure that all fittings and connections are vacuum tight so that premature checking does not take place. Premature checking occurs when the ball in the air check falls to the bottom before all brine is drawn out of the brine tank.

Brine Tank Overflow Line Connection

In the event of a malfunction, the brine tank overflow connection directs overflow to the drain instead of spilling it on the floor where it could cause water damage. Complete the following steps to connect the overflow fitting to the brine tank:

1. Locate the fitting hole on the side of the brine tank.
2. Insert the overflow fitting (not supplied) into the tank and tighten with the plastic thumb nut and gasket as illustrated in Figure-10.

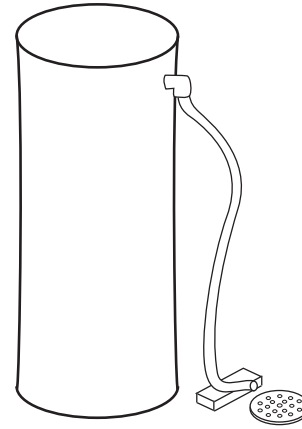

Figure 10 Brine Tank Drain

3. Attach a length of 1/2-inch (1.3-cm) tubing (not supplied) to the fitting and run to the drain.

Note: Do not elevate the overflow line higher than 3 inches (7.6 cm) below the bottom of the overflow fitting. Do not tie into the drain line of the control unit. The overflow line must be a direct, separate line from the overflow fitting to the drain, sewer, or tub. Allow an air gap as in the drain line connection, Figure-10.

WARNING: Never insert drain line directly into a drain, sewer line, or trap (Figure-11). Always allow an air gap between the drain line and the waste water to prevent the possibility of sewage being back-siphoned into the conditioner. Secure the end of the drain line to prevent it from moving (Figure-11).

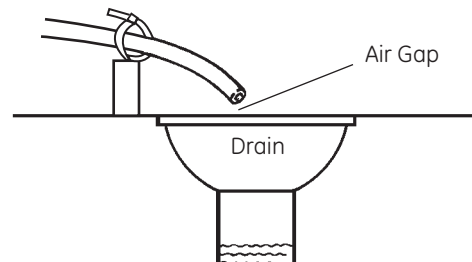

Figure 11

Brine Tank

Normally one brine tank is needed for each tank. The use of block salt or rock salt is not recommended. If a brine shelf is used, two brine tanks are required. This is due to the increased time needed to produce a concentrated brine solution when using a salt shelf. If rapid multiple exhaustions and regenerations are anticipated, do not use a salt shelf even if two brine tanks are used.

Electrical Connection

Caution: This valve and control are for dry location use only unless used with a Listed Class 2 power supply suitable for outdoor use.

The 764 Series control operates on a 12-volt alternating current power supply. This requires use of the Pentair Water supplied AC adapter. A variety of AC adapters are available from your supplier for different applications. They include:

AC Adapter	Input Voltage	Application	Part Number
Standard wall-mount	120V 60 Hz	UL listed for indoor installations	1000811
Outdoor rated	120V 60 Hz	UL listed for outdoor installations	1235448

120 VAC AC Adapters:

Make sure power source matches the rating printed on the AC adapter.

Note: The power source should be constant. Be certain the AC adapter is not on a switched outlet. Power interruptions longer than 8 hours may cause the controller to lose the time and day settings. When power is restored, the control will display four dashes (- - :- -) indicating that the day and time settings must be re-entered

Note: Do not connect power by plugging in the transformer at this time. Doing so may cause difficulty in properly placing the unit into operation.

Caution: Plumbing cannot be used for electrical grounding when metal inlet and outlet piping is connected to a non-metal valve.

Connect the inlet and outlet piping together using a grounding strap or clamp to establish continuity.

Disinfection of Water Conditioning Systems

The materials of construction in the modern water conditioning system will not support bacterial growth, nor will these materials contaminate a water supply. During normal use, a conditioner may become fouled with organic matter, or in some cases with bacteria from the water supply. This may result in an off-taste or odor in the water.

Some conditioners may need to be disinfected after installation and some conditioners will require periodic disinfection during their normal life.

Depending upon the conditions of use, the style of conditioner, the type of ion exchanger, and the disinfectant available, a choice can be made among the following methods.

Sodium or Calcium Hypochlorite

These materials are satisfactory for use with polystyrene resins, synthetic gel zeolite, and bentonites.

5.25% Sodium Hypochlorite

These solutions are available under trade names such as Clorox¹. If stronger solutions are used, such as those sold for commercial laundries, adjust the dosage accordingly.

1. Dosage

- Polystyrene resin; 1.2 fluid ounce (35.5 mL) per cubic foot.
- Non-resinous exchangers; 0.8 fluid ounce (23.7 mL) per cubic foot.

2. Regenerant tank conditioners

- A. Backwash the conditioner and add the required amount of hypochlorite solution to the well of the regenerant tank. The regenerant tank should have water in it to permit the solution to be carried into the conditioner.
- B. Proceed with the normal regeneration.

Calcium Hypochlorite

Calcium hypochlorite, 70% available chlorine, is available in several forms including tablets and granules. These solid materials may be used directly without dissolving before use.

1. Dosage

- A. Two grains (approximately 0.1 ounce (3 mL) per cubic foot.

2. Regenerant tank conditioners

- A. Backwash the conditioner and add the required amount of hypochlorite to the well of the regenerant tank. The regenerant tank should have water in it to permit the chlorine solution to be carried into the conditioner.
- B. Proceed with the normal regeneration.

1. Clorox is a trademark of the Clorox Company.

System Operation

Treated Water (Downflow)

Untreated water is conditioned as it flows through the resin bed and up the riser.

Backwash (Upflow) – Cycle C1

Flow is reversed by the control valve, directed down the riser, up through the resin bed and sent to drain. The bed is expanded and debris is flushed to the drain.

Regenerant Draw (Downflow) – Cycle C2¹

Water passes through the injector and regenerant is drawn from the regenerant tank. The regenerant is directed to the resin bed. The hardness ions are displaced by sodium ions. Regenerant draw is completed when the air check closes.

Slow Rinse (Downflow) – Cycle C3¹

Water flow moves the regenerant through the resin at a specific rate and rinses to the drain. The resin is regenerated.

Repressurization – Cycle C4

Pressure is balanced in the valve before continuing the regeneration.

Fast Rinse (Downflow) - Cycle C5

Water passes through the resin bed and up through the riser to drain. All remaining regenerant residual is rinsed from the resin bed.

2nd Backwash (Upflow) - Cycle C6

Flow is identical to C1 Backwash. The resin is reclassified.

2nd Rinse (Downflow) - Cycle C7

Flow is identical to C5 Fast Rinse. The resin bed is rinsed to quality.

Regenerant Refill – Cycle C8

Water is directed to the regenerant tank to create regenerant for the next regeneration.

Cycle Water Flows

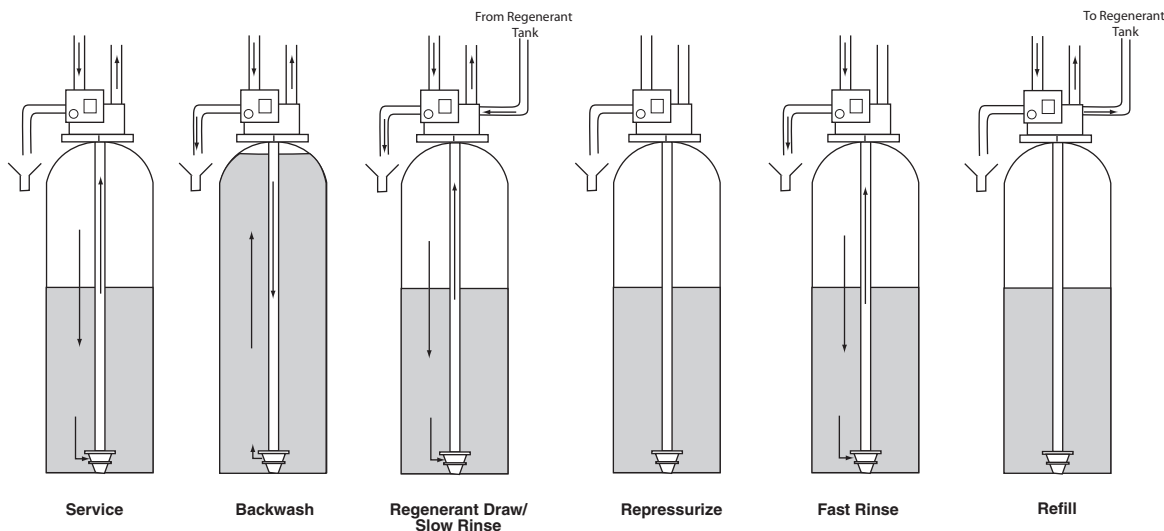

1. The camshaft does not change position between the C2 and C3 cycles. C3 is not displayed.

Camshaft Cycle Positions

The front end of the camshaft has an indicator cup. The cup has slots in the outer edge and cycle numbers on the inside face (Figure-12).

Remove the cover and look over the top of the 764 control to view the cycle numbers. The number at the top indicates the current cycle position of the control valve. The corresponding slot for the number is positioned at the optical sensor, which is rotated approximately 90 degrees out of phase.

Note: If electrical power is not available, the camshaft can be rotated counterclockwise by hand if the motor is removed.

Cycle Indicators:

- 0 = Treated Water
- 1 = Backwash Cycle
- 2 = Regenerant Draw Cycle
- 3 = Slow Rinse Cycle
- 4 = System Pause
- 5 = Fast Rinse Cycle 1
- 6 = 2nd Backwash
- 7 = 2nd Fast Rinse
- 8 = Regenerant Refill

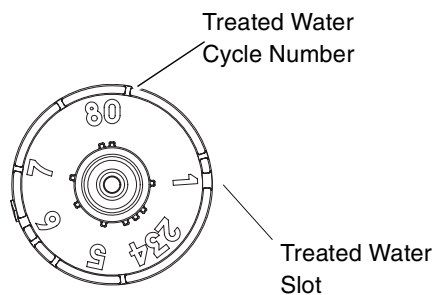

Figure 12

Valve Disc Location/Function

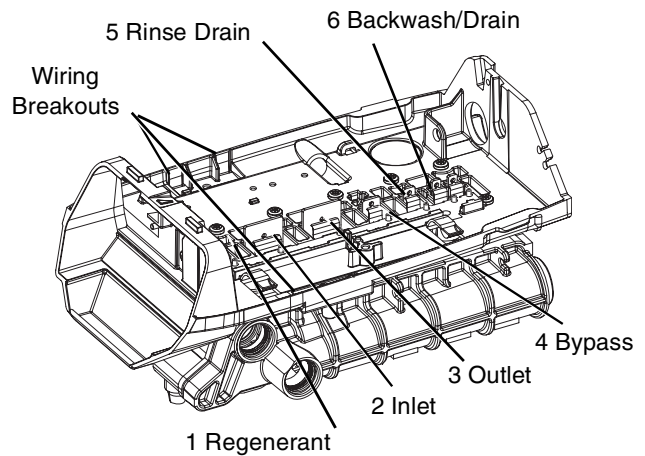

Figure 13 255 Valve

764 Control Operation

Power Loss Memory Retention

The 764 control features battery-free Time of Day and Day of Week retention during loss of power. A super capacitor is designed to keep time for 8 to 24 hours depending on the installation. If the super capacitor is exhausted the Logix control will display four dashes (- - :- -) immediately upon power up. The Time of Day and Day of Week must be reset.

All other programmed parameters are stored in the static memory and are retained.

Display Icons & Cursors

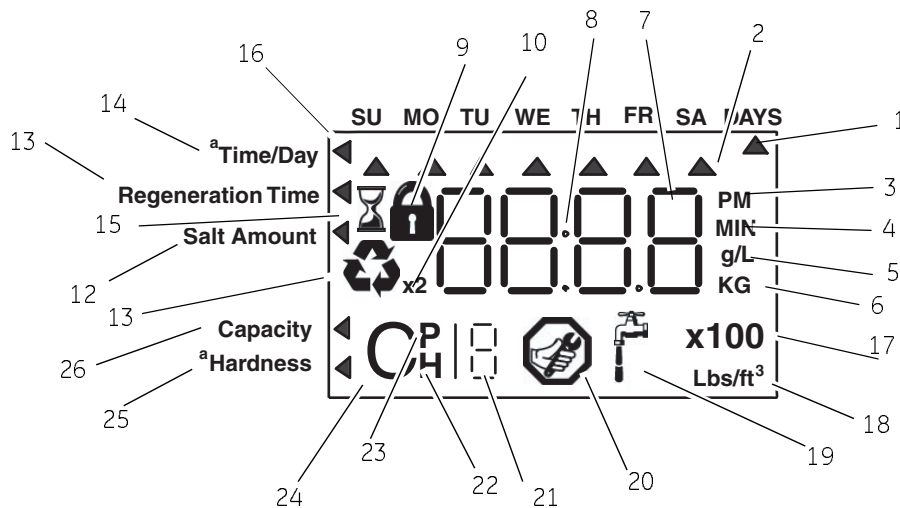

^a If your Logix 764 controller was purchased as a filter control, the overlay will show: Time/Day, Backwash Time, Backwash Length and Capacity.

Note: In normal operation and during programming, only a few of the icons will actually be displayed.

- This cursor is displayed when the days between regeneration are being programmed (used with .5 to 99 day regeneration programming).
- One of these cursors is displayed to indicate which day will be programmed into the controller.
- "PM" indicates that the time displayed is between 12:00 noon and 12:00 midnight (there is no AM indicator). PM indicator is not used if clock mode is set to 24-hour.
- When "MIN" is displayed, the value entered is in minute increments.
- When g/L is displayed, the value for regenerant amount entered is in grams/Liter.
- When "Kg" is displayed, the value entered is in kilograms or kilograins.
- Four digits used to display the time or program value. Also used for error codes.
- Colon flashes as part of the time display. Indicates normal operation (742 only).
- Locked/unlocked indicator. In Level I programming this is displayed when the current parameter is locked-out. It is also used in Level II programming to indicate if the displayed parameter is locked (icon flashes) when controller is in Level I.
- When "x2" is displayed, a second regeneration has been called for.
- The recycle sign is displayed (flashing) when a regeneration at the next time of regeneration has been called for. Also displayed (continuous) when in regeneration.
- The display cursor is next to "SALT AMOUNT" when programming the amount of regenerant. If the controller is on a 3-cycle filter then backwash time is programmed.
- The display cursor is next to "REGENERATION TIME" when programming the time of regeneration and the days of regeneration.
- The display cursor is next to "TIME/DAY" when programming the current time and day.
- The hourglass is displayed when the motor is running. The camshaft should be turning.
- These cursors appear next to the item that is currently displayed.
- X100 multiplier for large values.
- When Lbs/ft³ is displayed the value for regenerant amount entered is in pounds/cubic foot.
- Faucet is displayed when the current flow rate is displayed. Control may show the faucet and "0", indicating no flow.
- Maintenance interval display turns on if the months in service exceed the value programmed in P11.
- Used with #24, #25, and #26. Displays valve in service, a sequence number or a value.
- History Values (H). The number displayed by #23 identifies which history value is currently displayed.
- Parameter (P). Displayed only in Level II Programming. The number displayed by #23 identifies which parameter is currently displayed.

- 24. Cycle (C). The number displayed by #23 is the current cycle in the regeneration sequence.
- 25. Hardness setting
- 26. Capacity display—shows estimated system capacity.

Keypad — Buttons

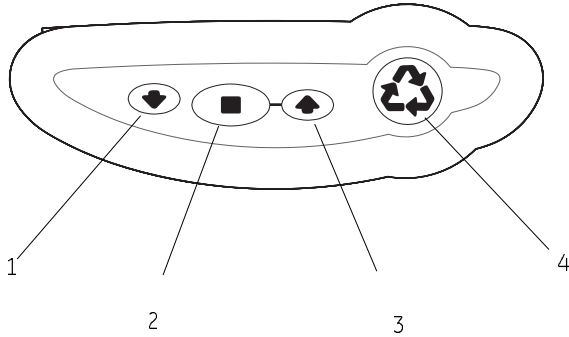

Figure 14

- 1. DOWN arrow. Generally used to scroll down or increment through a group of choices.
- 2. SET. Used to accept a setting that normally becomes stored in memory. Also used together with the arrow buttons.
- 3. UP arrow. Generally used to scroll up or increment through a group of choices.
- 4. Regenerate. Used to command the controller to regenerate. Also used to change the lock mode.

Note: If a button is not pushed for thirty seconds, the controller returns to normal operation mode. Pushing the Regenerate button immediately returns the controller to normal operation.





Programming Conventions

The 700 series controller is programmed using the buttons on the keypad. The programming instructions are described two ways whenever a section has keypad input.

First, a table shows simplified instructions. Second, text follows that describes the action. In each table:

"Action" lists the event or action desired.

"Keys" are listed as:

-  UP for up arrow
-  DOWN for down arrow
-  SET for set
-  REGEN for regeneration

"Duration" describes how long a button is held down:

P/R for press and release

HOLD for press and hold

X sec for a number of seconds to press the button and hold it down

"Display" calls out the display icons that are visible.

Placing Water Conditioning System Into Operation

After you have performed the installation steps, the conditioner will need to be placed into operation.

Follow these steps carefully, (pages 17 to 22) as they differ from previous valve instructions.

Note: All Logix 764 controls will be shipped in the service (treated water) position. Do not rotate the camshaft before performing the following steps.

The incoming supply water should be turned off.

Remove air from tank(s).

1. Position the bypass valve(s) to the in service (not in bypass) position.
2. Open the nearest water faucet completely.
3. Open the incoming water supply valve slowly to the quarter open position.

Note: Do not plug in the power supply until step 5. The tank(s) will fill with water. The air will exit through the faucet. When water flows steady from the faucet, the tank(s) are purged.

4. Turn off the faucet then turn off the incoming water supply.

Power-up the Control

5. Plug the transformer into a non-switched outlet. The display will show the valve type that was loaded from memory.

If this is the first time the control is powered up the display will show 255A.

6. Use the  or  buttons to increment through the available selections, Table-1.

Table-1 Preprogrammed Values

Type	Valve			Connection - inches
255 A	255	Twin Alternating	8-cycle conditioner	3/4
273 A	273		3-cycle filter	1
278 A	278		5-cycle conditioner	1
293 A	293		3-cycle filter	2
298 A	298		5-cycle conditioner	2
255 P	255	Twin Parallel	8-cycle conditioner	3/4
273 P	273		3-cycle filter	1
278 P	278		5-cycle conditioner	1
293 P	293		3-cycle filter	2
298 P	298		5-cycle conditioner	2
255 L	255	Single Tank Remote Regeneration or Multi-Single Tank Lockout	8-cycle conditioner	3/4
263 L	263		8-cycle conditioner	1
268 L	268		3-cycle filter	1
273 L	273		3-cycle filter	1
278 L	278		5-cycle conditioner	1
293 L	293		3-cycle filter	2
298 L	298		5-cycle conditioner	2

For the next steps you may want to remove the cover to watch the camshaft movement.

7. Press  to enter the valve type and the proper preprogrammed valves for your application:
 255A for Twin Alternating
 255P for Twin Parallel
 255L for single or multiple tanks with regeneration lockout or remote regeneration start
8. The display will show - - -. Select media volume or "F" for filter setup. If a number or "F" is displayed the resin volume or a filter valve has been preprogrammed.
 Finish programming the Logix 764 control using the Level I programming guide.

For a 255A system: the control will automatically synchronize the cam positions.

Tank 1 will move to standby
 Tank 2 will move to service

E r r 3 will be displayed when the Tank 1 cam is moving. *E r r 4* will be displayed when Tank 2 cam is moving.

For a 255P system:

Tanks 1 and 2 will move to service if not already in service.

For a 255L system:

The tank(s) will move to service if not already in service.

These cam movements may take up to 5 minutes.

Table 2

Resin Volume - 0.25 ft³ and 5 Liter Steps			
	Resin Volume		
Tank Dia (inches)	Injector	US	Metric
6	E	0.25	5
6	E		10
7	F	0.50	15
8	G	0.75	20
9	H		25
9	H	1.00	30
10	J	1.25	35
10	J	1.50	40
12	K		45
12	K	1.75	50
12	K	2.00	55
13	L		60
13	L	2.25	65
14	L	2.50	70
14	L		75
14	L	2.75	80
14	L	3.00	85
14	L		90
14	L		95
14	L		100

Level I Programming - 764 Control with 255 Valve, 8 Cycle Conditioner

Screen	Buttons to Press	Description	Range
	then ↓ or ↑ press ■	1. Resin Volume Select correct resin volume	Cubic feet: 0.25 to 3.00
	press ■ then ↓ or ↑ press ■	2. Time of Day (12 hr.) Set to time of day Note: Setting includes PM indicator.	
	press ■ then ↓ or ↑ press ■	3. Day of Week Set to actual day of the week	
	press ■ then ↓ or ↑ press ■	4. Time of Regeneration Set to desired time of regeneration	
	press ■ then ↓ or ↑ press ■	5. Days Override Leave at 0 to disable or Set to desired days between regeneration	Days: 1 to 99
	press ■ then ↓ or ↑ press ■	7. Salt Dosage Set to desired dosage lbs per cubic feet of resin	Lbs/ft ³ : 3 to 18
	press ↓ to override press ■ then ↓ or ↑ press ■	8. Capacity Capacity calculated by Logix Control Use to OVERRIDE calculated capacity	Kilograins: 1 to 900
	press ■ then ↓ or ↑ press ■	9. Hardness Set to actual water hardness in grains per gallon	Grains/gal: 3 to 200

Control programming is complete

Note: If one of the following conditions occur:

- control displays Err3 and goes to home position or
- power outage discharges the supercapacitor and when power is restored and the time of day is reset; the Regen Icon will begin flashing. This indicates that a delayed regeneration will occur at the next programmed time of regeneration. If a delayed regeneration is not desired, press the REGEN Button to disable the delayed regeneration and the system will regenerate by water usage.

Placing Water Conditioning System Into Operation (continued)



Caution: If your system is a 255A (Alternating) go to “Quick Cycling the Control for 255A Systems”.

Quick Cycling the Control 255L and 255P

It is required that the control be quick cycled to specific regeneration cycles when placing the conditioner into operation. This will ensure that all of the air in the tank and valve is purged. The process also provides a check for leaks and functioning of the brine system. Please perform the following steps for quick cycling the control, before proceeding to start-up.

1. With the control in the treated water position, Press and hold the REGEN button on the controller for 5 seconds. This will initiate a manual regeneration. The control will display a solid hourglass indicating that the motor and camshaft are turning to the backwash cycle (C1). When the control reaches the backwash cycle, the total regeneration time remaining will be displayed. Pressing the SET button will display the specific cycle time remaining.
2. Press and release the UP and SET buttons to move the control to the Regenerant Draw cycle (C2).
3. Repeat Step 2 to advance to each cycle.

Before the final filling of the media tank with water check that:

- the nearest water faucet is completely closed.
- the valve drain line is properly routed to a drain
- the regenerant tank is empty and the regenerant hose is connected to the valve
- the water supply valve is off.

Note: The control can be sent directly back to the treated water position from any regeneration cycle. Press the UP and SET buttons (about 5 seconds) until the hourglass icon begins flashing. The control will now skip all remaining regeneration cycles.

255 Alternating and parallel tank systems have one Logix 764 control that is mounted on tank 1. Tank 2 has a blank faceplate and the valve is controlled by the Logix 764 control on tank 1.

4. Add water to the regenerant tank.
 - A. With a bucket or hose add approximately 4 gallons (15 liters) of water to the regenerant tank.

- B. If the tank has a salt platform in the bottom of the tank, add water until the water level is approximately 1 inch (25 mm) above the platform.

Note: It's recommended that you do not put regenerant into the tank until after the control valve has been put into operation. With no regenerant in the tank, it is much easier to view water flow and motion in the tank.

5. Press and hold the  button on the controller for 5 seconds. This will initiate a manual regeneration. The control will display a solid hourglass indicating that the motor and camshaft are turning to the backwash cycle (C1). When the control reaches the backwash cycle, the total regeneration time remaining will be displayed. Pressing the SET button will display the specific cycle time remaining.
6. While the controller is in cycle C1 (Backwash), open the water supply valve very slowly to approximately the ¼ open position. Water will begin to enter the media tank. Any air remaining will begin to be purged to drain as the media tank fills with water.



WARNING: If opened too rapidly or too far, media may be lost out of the tank into the valve or the plumbing. In the ¼ open position, you should hear air slowly escaping from the valve drain line.

When all of the air has been purged from the media tank (water begins to flow steadily from the drain line), open the main supply valve all of the way. This will purge the final air from the tank.

Allow water to run to drain until the water runs clear from the drain line. This purges any debris from the media bed.

7. Check Regenerant Draw.
 - A. Quick cycle the control to the C2 regenerant draw/slow rinse position .

Note: As you advance through each cycle there will be a slight delay before you can advance to the next cycle. There will be a pause after the regenerant draw and slow rinse cycles. This cycle (C4) is a repressurization cycle and is designed to allow the water pressure to equalize on each side of the valve discs. Allow the control to repressurize (3 minutes) before cycling the control to the regenerant tank refill position.

- B. C2 will be displayed. With the control in this position, check that the water is being drawn out of the regenerant tank. The water level in the regenerant tank should recede very slowly.
 - C. Observe that water is being drawn from the regenerant tank for at least three minutes. If the water level does not recede, check all regenerant line connections for air leaks.
8. If the water level is receding from the regenerant tank you can quick cycle the control to the C8 Regenerant tank refill position.
 - A. The control will cycle to the regenerant tank refill cycle, and water will be directed down through the regenerant line to the regenerant tank. Let the water flow through the line until all air bubbles have been purged from the line. Note: Do not let the water flow down the line to the tank for more than one to two minutes, or the tank may overflow.
 9. Repeat steps 4 and 8 for each additional tank.
 10. Finally, turn on a faucet plumbed after the water conditioner. Run the faucet until the water runs clear.
 11. Add the appropriate amount of regenerant to regenerant tank.

The Water Conditioning System is Now Fully Operational

Note: After any control reset (valve type or system change, etc.) it is necessary to initiate a manual regeneration and quick cycle through it. This will ensure the control and cam are synchronized. If not synchronized *E r r 3* will display and the control will drive cams to the correct position for valve and system type programmed.



Quick Cycling the Control for 255A Systems

It is required that the control be quick cycled to specific regeneration cycles when placing the conditioner into operation. This will ensure that all of the air in the tank and valve is purged. The process also provides a check for leaks and functioning of the brine system.

After the initial power up and programming, tank 1 will be in standby and tank 2 will be in service.

Before the final filling of the media tanks with water, check that:

- the nearest water faucet is completely closed.
- the valve drain line is properly routed to a drain.
- the regenerant tank is empty and the regenerant hose is connected to the valve.
- the water supply valve is partially open
- valve bypasses are in service positions.

During this process the valves will need to be quickly advanced to the next cycle. To quick cycle press  and  after the regeneration cycle has started.

255 Alternating tank systems have one Logix 764 control that is mounted on tank 1. Tank 2 has a blank faceplate and the tank 2 valve is controlled by the Logix 764 control on tank 1.

To Place the 255 Alternating System into Operation:

1. Press and hold the  button for 5 seconds. This will start the first regeneration.

Note: Once the valve has reached the cycle (visible on the display and camshaft has stopped turning), quick cycle to the next cycle. This is especially recommended for the C8 cycle. Overfilling the regenerant tank will affect the brine and future regen cycles.

Note: It is recommended that you do not put regenerant into the tank until after the control valve has been put into operation. With no regenerant in the tank, it is much easier to view water flow and motion in the tank.

Tank 1 moves through cycles:

C5 - Fast Rinse

As water enters the tank, air will be forced out the drain line. Once water fills the tank it will then discharge out the drain line. Quick cycling the control can now be used to advance through the remaining cycles

C8 - Regenerant Refill; the aircheck is filled and flow to the regenerant tank is visible

Quick cycle Tank 1 to service

then--

Tank 2 moves through cycles:

C1 - Backwash

As water enters the tank, air will be forced out the drain line. Once water fills the tank it will then discharge out the drain line. Quick cycling the control can now be used to advance through the remaining cycles

C2 - Regenerant Draw; the regenerant tank should have water in it. As the draw occurs the level will go down.

C3- Slow Rinse

C4 - Standby

Both tanks have now been purged of air. The water supply valve can be fully opened.

2. Press and hold the  button for 5 seconds. This will start the second regeneration.

Quick cycle as Tank 2 moves through cycles:

C5 - Fast Rinse

C6 - 2nd Backwash

C7 - 2nd Rinse

C8 - Regenerant Refill; the aircheck is filled and flow to the regenerant tank is visible.

Quick cycle to Service

then--

Quick cycle as Tank 1 moves through cycles:

C1 - Backwash

C2 - Regenerant Draw; the regenerant tank should have water in it. As the draw occurs the level will go down.

C3 - Slow Rinse

C4 - Standby

At this point Tank 1 is fully operational.

3. Press and hold the  button for 5 seconds. This will start the third regeneration. After this step both tanks will be ready.

Quick cycle as Tank 1 moves through cycles:

C5 - Fast Rinse

C6 - 2nd Backwash

C7 - 2nd Rinse

C8 - Regenerant Refill

Quick cycle to Service

then--

Quick cycle as Tank 2 moves through cycles:

C1 - Backwash

C2 - Regenerant Draw; the regenerant tank should have water in it. As the draw occurs the level will go down.

C3 - Slow Rinse

C4 - Standby

Both tanks are now ready.

4. Turn on a faucet plumbed after the water conditioner. Run the faucet until the water runs clear.
5. Add water to the regenerant tanks.
 - A. With a bucket or hose, add water until approximately 4 gallons (15 liters) of water in each regenerant tank.
 - B. If the tank has a salt platform in the bottom of the tank, add water until the water level is approximately 1 inch (25 mm) above the platform.

The Alternating Water Conditioning System is Now Fully Operational

Note: After any control reset (valve type or system change, etc.) it is necessary to initiate a manual regeneration and quick cycle through it. This will ensure the control and cam are synchronized. If not synchronized *E r r E* will display and the control will drive cams to the correct position for valve and system type programmed..

In Service Display

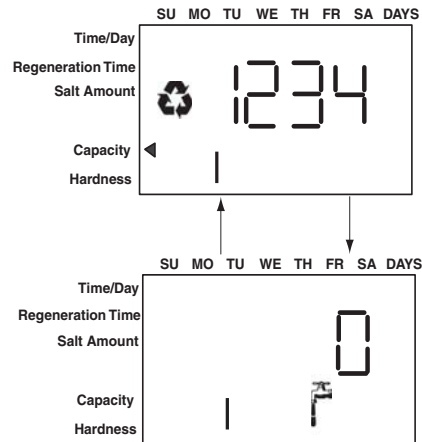

Logix 764 Electronic Multi-Tank - "A" Alternating Control:

Service display — The number of the Tank in Service (small digit next to CPH position) and Alternating Capacity Remaining and Flow Rate with Faucet icon of Tank in Service

Logix 764 Electronic Multi Tank - "P" Parallel Control:

Service Display — alternating three items

Capacity remaining for Tank 1 with digit "1" displayed

Capacity remaining for Tank 2 with digit "2" displayed

System Flow Rate (Tank 1 + Tank 2 added) with Faucet icon

Logix 764 Electronic Multi Tank — "L" Lock Out Control

Service Display — Alternating Capacity Remaining and Flow Rate with Faucet icon "L" displayed indicating lockout signal is active. Blinking "L" and Lock icon if lockout signal is active and control is ready to perform regeneration.

Note: The faucet icon is displayed on all the Logix 764 controls when there is flow. The 764 will show the faucet icon when the flow rate is displayed, even if the flow rate is zero. If the flow rate is zero, the faucet will turn off when the capacity is displayed.

Note: In-service flow rate display can be replaced with a clock display using Level II programming.

Programming Overview

The 764 control includes multiple program levels that allow the Water Treatment Professional to customize the system for many water conditions. Additionally, historical data can be viewed allowing quick and easy

troubleshooting. In most cases Level I programming is all that is required to set up the water conditioning system for proper operation. A brief description of each program level is listed below.

Level I Used to program control for normal applications.

Level II (P-Values) Allows the installer to customize programming for non-standard applications.

Level III (C-Values) Allows the installer to adjust the length of select cycles for non-standard applications.

Level IV History (H-Values) Allows access to historical information for troubleshooting the system.

Note: If a button is not pushed for thirty seconds, the control returns to normal operation mode.

Level I Programming

The 764 control can be quickly programmed by following the sequential procedure in the section "Placing Water Conditioning System Into Operation".

Level I program parameters are those that can be accessed by pressing the UP or DOWN buttons.

- Resin Volume Setting: Set to match the volume (cubic feet) of resin in the mineral tank.
- Time of Day: Includes PM indicator. Can be set to display as a 24-hour clock. See Level II programming
- Day of Week: Set to actual day of the week.
- Time of Regeneration: Fully adjustable. Default is 2:00 AM.
- Days Override: Range 0.5 to 99 days. Leave at 0 to disable.
- Salt Dosage: Set at pounds of salt per cubic foot of resin in the conditioner tank.

Note: When the control is set up for a twelve-hour clock a PM indicator will illuminate when the displayed time is in the PM hours. There is no AM indicator.

Level II Programming – P Values

Level II program parameters can be adjusted to fine-tune the conditioner's operation. The parameters are accessible by pressing and holding the UP and DOWN buttons until the control displays a "P" value. Note: The control must be in the home position to change settings. See Table-3 for Level II parameters. Typically the

Level II parameters will not need to be adjusted as the default settings accommodate most applications. Contact your Water Treatment Professional before attempting any programming.

Table-3

	Description	Range	Minimum Increments	Default	Units	Notes
P9	Units of Measure	0-1	1	(2)		0 = US 1 = Metric
P10	Clock Mode	0-1	1	(2)		0 = 12 hour clock; flow rate service display 1 = 24 hour clock; flow rate service display 2 = 12 hour clock; Time of Day service display 3 = 24 hour clock; Time of Day service display
P11	Service Interval	0-250	1	0	Months	Uses 30 days for each month; 0 = off
P12	Remote regeneration switch delay	3-250	1	60	seconds	Time remote switch must be active to start regeneration.
P13	Chlorine Generator Options (not used on "A" and "P" systems)	0-2	1	0		0 = No chlorine generator 1 = salt check only 2 = generate chlorine
P14	Refill Rate	1-700	1	(1)	gpm x 100	
P15	Draw Rate	1-700	1	(1)	gpm x 100	
P16	Reserve Type (not used for alternating mode)	0-3	1	0		0 = variable reserve delayed regeneration 1 = fixed reserve delayed regeneration 2 = variable reserve immediate regeneration 3 = fixed reserve immediate regeneration
P17	Initial average or fixed reserve (not used for alternating mode)	0-70	1	30	% of Capacity	Depends on value entered in P16
P18	Flow sensor select	0-7	1	(1)		0 = internal magnum NHWB, 1, 6 = 1" Autotrol turbine 2, 7 = 2" Autotrol turbine 3 = User defined K-factor 4 = User defined Pulse Equivalent 5 = Internal Magnum HWB Values 6 & 7 are for single turbine configurations on twin alternating systems.
P19	K-factor or Pulse equivalent	1.00-99.99 0-9999	0.01 1	0.01 1		K-factor P18=3; Pulse Equivalent P18 = 4
Pr	Refill First *	0-1	1	0		0 = Refill first off 1 = Refill first on
Pd	Remote switch operation	0-1	1	0		0 = Immediate Regeneration after P12 time 1 = Delayed Regeneration after P12 time
Notes: (1) Default selected with valve type and resin volume. (2) Factory Default is "0" for North America units and "1" for World units.						

*Not used when control is programmed for twin alternating

Programming the Lockout Feature

All Level I parameters can be locked out when the control is in Level II programming. Simply press the REGEN button during Level II programming and a Lock Icon will appear indicating that the specific setting has been locked out. When locked out, the setting cannot be adjusted. To disable the Lock Out Feature, press the REGEN button when in Level II. The lock icon will not be displayed.

Salt Setting

The default P6 salt setting is set at 9 lbs/cu ft. Under normal circumstances this setting will provide the correct system capacity. This setting may be adjusted to change the exchange capacity.

Table 4 Exchange Capacity 255 Valve

Salt Setting lbs/cu ft	Exchange Capacity grains/cu ft	Salt Setting grams/Liter	Exchange Capacity grams/Liter
3	14100	50	33.6
4	18307	60	40.0
5	21160	70	44.5
6	23490	80	48.4
7	25460	90	51.8
8	27167	100	54.9
9*	28673	110	57.7
10	30019	120	60.2
11	31238	130	62.6
12	32350	140	64.8
13	33373	150	66.8
14	34320	170	70.4
15	35202	200	75.2
16	26027	230	79.3
17	26802	260	82.9
18	37533	290	86.1

*Default setting.

Level III Cycle Programming – C Values

Several Level III program parameters can be adjusted to fine-tune a valve operation for non-standard applications. Typically these parameters will not need to be adjusted as the default settings accommodate most applications. Contact your Water Treatment Professional before attempting any programming. The parameters are accessible by pressing and holding the UP and SET buttons until the display shows a “C” value.

Note: The control must be in the treated water position to change settings.

Table-5

C#	Description	Range	Minimum Increments	Default Setting	Notes
C1	Backwash	0 – 200	1 Min	14	Flow rate dictated by size of drain line flow controller
C2	Regenerant Draw	Not Adjustable	1 Min	See Notes	Automatically calculated from resin volume and salt dosage settings
C3	Slow Rinse	0 – 200	1 Min	See Notes	Automatically calculated from resin volume and salt dosage settings
C4	Repressurization	0 – 200	1 Min	3	Allows system to equalize water pressure across valve discs
C5	Fast Rinse	0 – 200	1 Min	6	Rinses residual regenerant from tank
C6	2nd Backwash	0 – 200	1 Min	1	Disperses non regenerated areas of the resin bed
C7	2nd Fast Rinse	0 – 200	1 Min	1	Rinses to Quality
C8	Regenerant Refill	Not Adjustable	1 Min	See Notes	Automatically calculated from resin volume and salt dosage settings

Level IV Viewing History - H Values

Historical information can be viewed by pressing the SET and DOWN buttons simultaneously, with the 764 control in the home position. Release both buttons when the control displays an “H” value. Press the UP or DOWN buttons to navigate to each setting.

Table-6 History Data

H#	Description	Range	Notes
H0 ^a	Initial Setting Value	Cubic Feet or Liters	Resin Volume
H1	Days since last regeneration	0 - 255	
H2	Current Flow Rate	Depends on turbine used	
H3	Water used today in gallons or/m ³ since Time of Regeneration	0-131,070 or 0-1,310.70 m ³	
H4	Water used since last regeneration in gallons or/m ³	0-131,070 or 0-1,310.70 m ³	
H5 ^a	Total water used since reset in 100s	0-999900 gallons or 0-9999 m ³	
H6 ^a	Total water used since reset in 1,000,000	4,294 x 10 ⁶ gal or 4264 x 10 ⁴ m ³	
H7	Average usage for Sunday in gallons or m ³	0-131,070 gallons or 0-1,310.70 m ³	
H8	Average usage for Monday in gallons or m ³	0-131,070 gallons or 0-1,310.70 m ³	
H9	Average usage for Tuesday in gallons or m ³	0-131,070 gallons or 0-1,310.70 m ³	
H10	Average usage for Wednesday in gallons or m ³	0-131,070 gallons or 0-1,310.70 m ³	
H11	Average usage for Thursday in gallons or m ³	0-131,070 gallons or 0-1,310.70 m ³	
H12	Average usage for Friday in gallons or m ³	0-131,070 gallons or 0-1,310.70 m ³	
H13	Average usage for Saturday in gallons or m ³	0-131,070 gallons or 0-1,310.70 m ³	
H14	Average service cycle	0-255 days	
H15 ^a	Peak Flow Rate	0-200 gpm or 1000 Lpm	
H16	Day and Time of Peak Flow Rate	Time and day that peak flow occurred	
H17 ^a	Months since service	0-2184 months	
H18	Water used since last regeneration - Tank 1	0-131,070 gallons or 0-1,310.70 m ³	
H19 ^a	Water used since last regeneration - Tank 2	0-131,070 gallons or 0-1,310.70 m ³	
Hr	Number of regenerations since last serviced	0-65536	

- a. H0, H5, H6, H15, H17, H19 values can be reset by pressing and holding  for 3 seconds while the values are being displayed.

Program Reset

The 764 control can be reset to original factory parameters when viewing the H0 parameter. Press and hold the SET button for three seconds while H0 is displayed. Release the button. All settings except for Time of Day and Day of Week will be reset. The 764 Logix control will now display the valve and system type. Refer to Level I Programming.

Note: After any control reset (valve type or system change, etc.) it is necessary to initiate a manual regeneration and quick cycle through it. This will ensure the control and cam are synchronized. If not synchronized *Err 3* will display and the control will drive cams to the correct position for valve and system type programmed.

Manual Regeneration Options

Refill First Option

Refill First is only available for single tank “L” and twin parallel “P” models.

The 764 control allows users to select when the refill cycle occurs. When Pr = 0 (default) refill occurs immediately after fast rinse. When Pr = 1 refill will not occur until just before a regeneration. This allows for a “dry” brine tank.

If refill first is selected, the valve will move to refill two hours before the start of backwash. After refill is complete, the valve moves back to service for a 2-hour brine make-up time. Regeneration then follows as normal, skipping refill.

By default, time of regeneration is set to midnight after refill first is selected.

Note: The tank in service (on-line) cannot be regenerated while the other tanks are isolated. Water for backwash would not be available.

The 764 control features several options that offer additional flexibility for manually regenerating the conditioner. On alternating systems the tank in standby will move through regeneration to service. The tank in service will move through regeneration to standby. On parallel systems, the tank with the lowest remaining capacity will regenerate.

Delayed Manual Regeneration

Press and release the REGEN button to start a delayed manual regeneration. The Regeneration icon on the display will flash indicating a regeneration will start when the time of day reaches the programmed time of regeneration. Pressing the REGEN button again will turn off the regeneration icon and cancel the delayed regeneration.

Immediate Manual Regeneration

Pressing and holding the REGEN button for three seconds starts an immediate manual regeneration. A solid regeneration icon will be displayed. The control will immediately begin a regeneration on the tank in service.

Delayed Second Regeneration

Pressing and releasing the REGEN button while the control is in regeneration will program the control for a delayed second regeneration. A flashing x2 icon next to the regeneration icon will appear indicating a second regeneration will start when the time of day reaches the programmed time of regeneration. The delayed second regeneration will be performed on the new tank in service. For alternating and parallel systems, each tank will regenerate once.

Double Immediate Manual Regeneration

Back-to-Back manual regenerations are initiated by pressing and holding the REGEN button for three seconds while the control is in the regenerating mode. A solid x2 icon next to the regeneration icon will appear indicating a second manual regeneration will start immediately after current regeneration is complete. For alternating and parallel systems each tank will regenerate once. Single tank systems will regenerate twice back-to-back.

Regeneration Modes for Parallel Systems

Parameter P16 is used to determine the method for demand initiated regeneration. Four regeneration modes are possible.

- P16 = 0, Delayed Regeneration with a Smart Reserve Regenerations will start only at the Time of Regeneration entered in P2. A tank is regenerated if the capacity remaining in that tank is below the minimum required capacity needed to meet the next days calculated water usage requirement. The next days water usage number is based on the daily average water usage held in memory plus a 20% reserve. If necessary both tanks will be regenerated sequentially beginning with the most exhausted tank.

This option allows the control to vary the reserve, and therefore the decision to regenerate, based on the actual daily water usage pattern for the location at which it is installed. See Table-7.

- P16 = 1, Delayed Regeneration with a Fixed Reserve Regenerations will start only at the Time of Regeneration entered in P2. A tank is regenerated if the capacity remaining in that tank is below the percentage entered in P17.

If either tank's capacity is overrun by 50% a regeneration will take place. The control will also cause both tanks to be regenerated sequentially the next Time of Regeneration regardless of how much water is used during that 24 hour period. This feature is to help recover a severely exhausted bed. See Table-8.

- P16 = 2, Immediate Regeneration - Fixed Reserve/DelayedRegeneration-Smart Reserve This option uses the features of both option 0 and option 3. This is the most versatile of regeneration options. Option number 2 provides all the advantages of variable reserve based on the actual amount of water that is used each day plus the capability to react to the excessive water usage days that occur occasionally. See Table-9.

- P16 = 3, Immediate Regeneration - Fixed Reserve Regenerations are started immediately when a tank reaches zero or when the system capacity remaining (capacity remaining in both tanks) drops below the reserve capacity programmed in P17. To prevent hard water this reserve should be set large enough to provide conditioned water during the regeneration of the most exhausted tank. See Table-10.

Table 7 TP16 = 0

Priority	Flow Rate	Continuous Soft Water	Efficiency
High	•		
Ave		•	•
Low			

Table 8 P16 = 1

Priority	Flow Rate	Continuous Soft Water	Efficiency
High	•		
Ave		•	
Low			•

Table 9 P16 = 2

Priority	Flow Rate	Continuous Soft Water	Efficiency
High		•	
Ave	•		•
Low			

Table 10P16 = 3

Priority	Flow Rate	Continuous Soft Water	Efficiency
High		•	•
Ave			
Low	•		

Wiring Diagrams

Connecting the Logix 764 Twin Alternating or Parallel Controls

The twin sensor and extension cables are used for twin unit parallel and alternating applications. Four standard connections are required for operation; the power transformer, the flow sensor, motor/optical sensor, and the connection between tank 1 and tank 2 controls.

Figure-15 outlines these standard features.

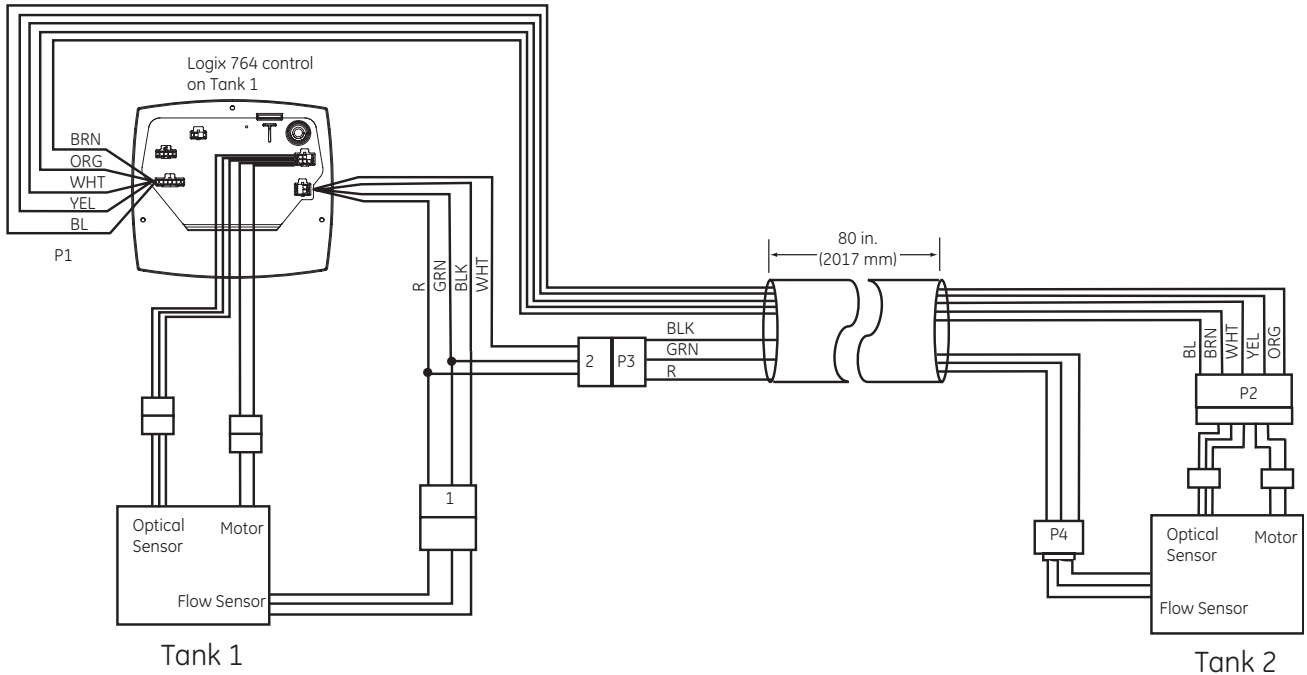
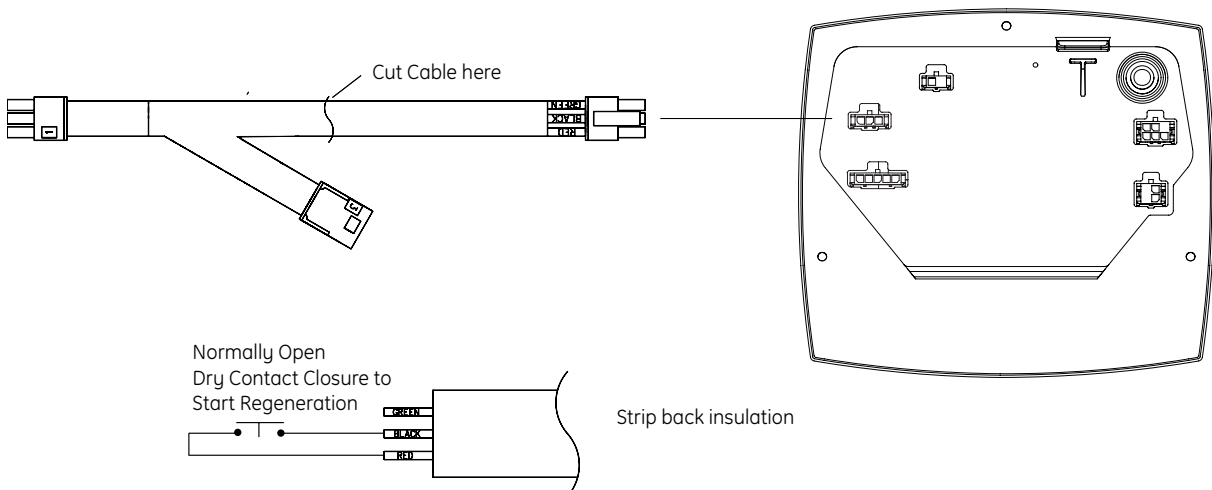

Figure 15

Remote Regeneration Start



Note: Cable PN 3020228 sold separately.

Figure 16

Connecting the Logix 764 Multi Single Tank Control

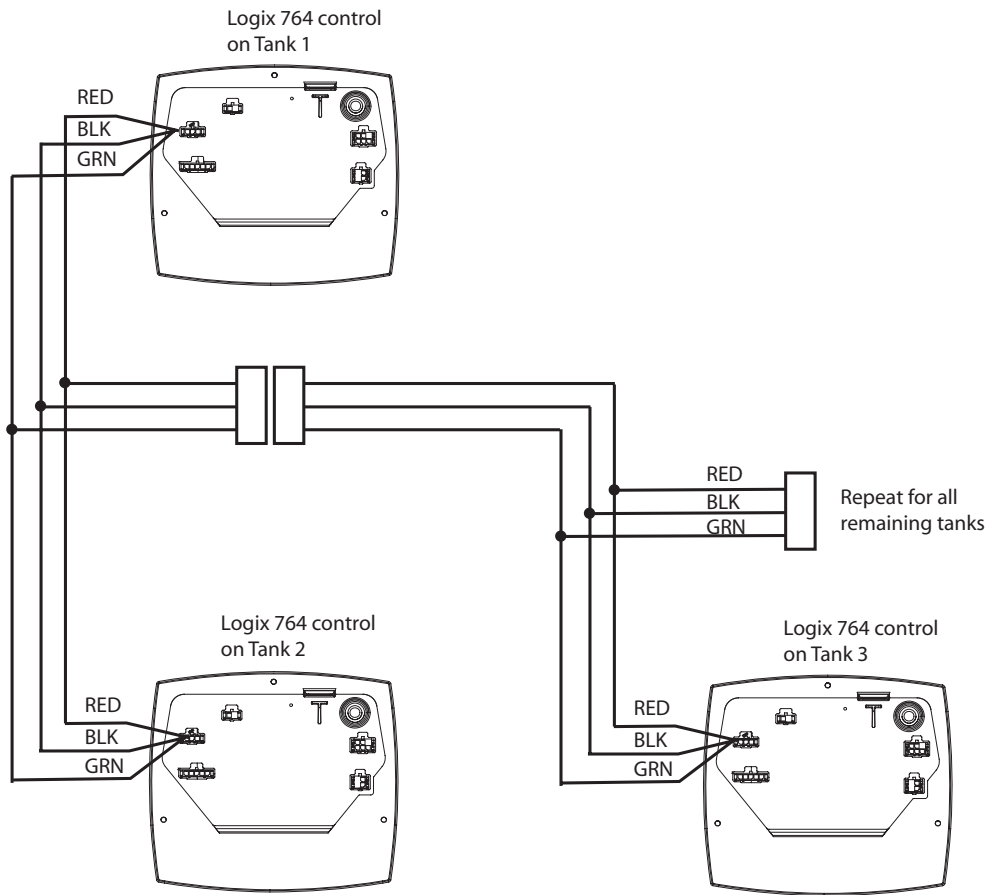

Note: Cable PN 3020228 sold separately.

Figure 17

Parts Lists

255 Exploded View & Parts List

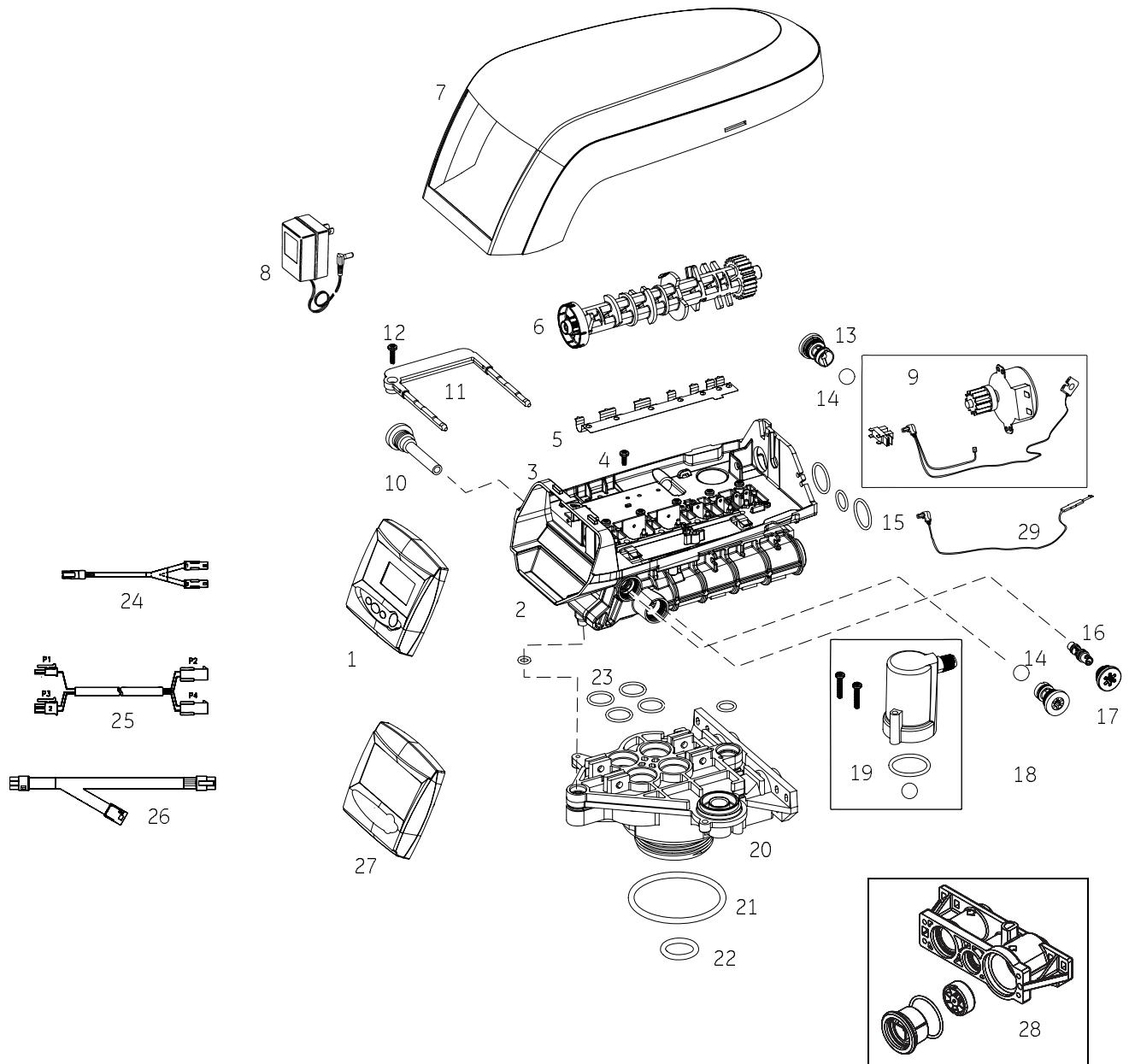

Item	Part Number	Description	Qty.	Item	Part No.	Description	Qty.
1	3014650	764 Series Control	1	17	1000269	Injector Cap with O-Ring	1
2	1244650	Valve Assembly w/o Flow Controls	1	18	1243511	0.33 Refill Ball & Cone Type Flow Controller	1
3	1235340	Top Plate	1	19		Air Check Kit	1
4	1234170	Screw, Top Plate	12		1032416	3/8 -inch male	
5	1235341	Valve Disc Spring, 255 Valve	1		1032417	1/4-inch NPT male threads	
6	1236251	Cam 255 Logix Valve, Twin Tan	1	20	1033784	Tank Adapter	1
7	1236246	Cover, Grey	1	21	1010429	O-Ring, Tank	1
8	1000811	AC Adapter, North American	1	22	1232370	O-Ring, Riser	1
9	3019221	Motor/Optical Cable	1	23	1001404	O-Ring Group, Tank Adapter	
10	1000226	Screen/Cap Assembly w/O-Ring	1	24	3016715	Assy, Sensor Cable Logix Twin	1
11	1031402	Locking Bar, English		25	3016775	Assy, Cable Extension 3 m (9.8 ft), Logix Twin	1
12	1006093	Screw, Locking Bar		26	3020228	Assy, Cable Remote Start/Multi-Tank	
13		Drain Control Assembly:	1			Lockout, 3 m (9.8 ft)	1
	1000208	No. 6 (10 gpm; 3.8 Lpm)		27	1254886	Secondary Faceplate (blank)	1
	1000209	No. 7 (1.3 gpm; 4.9 Lpm)		28	1032347	Assy, Adapter 1-inch Turbine	1
	1000210	No. 8 (1.6 gpm; 6 Lpm)		*	1000250	Valve Disc Kit	1
	1000211	No. 9 (2 gpm; 7.6 Lpm)		*	1040769	256 Bypass Valve Kit (Optional)	1
	1000212	No. 10 (2.5 gpm; 9.5 Lpm)		*	1267808	Valve Skirt	1
	1000213	No. 12 (3.9 gpm; 14.8 Lpm)		29	1235446	Turbine Cable	1
	1000214	No. 13 (4.5 gpm; 17 Lpm)					
	1000215	No. 14 (5.3 gpm; 20 Lpm)					
14	1030502	Ball, Flow Restrictor	1				
15	1040459	O-ring Group, Piping Boss					
16		Injector Options:	1				
	1035730	"E" Injector, Yellow, 6-inch tank					
	1035731	"F" Injector, Peach, 7-inch tank					
	1035732	"G" Injector, Tan, 8-inch tank					
	1035733	"H" Injector, Lt Purple 9-inch tank					
	1035734	"J" Injector, Lt Blue 10-inch tank					
	1035735	"K" Injector, Pink 12-inch tank					
	1035736	"L" Injector, Orange, 13 & 14-inch tank					

* Not Shown on Drawing

Bypass Valve and Turbine Adapter

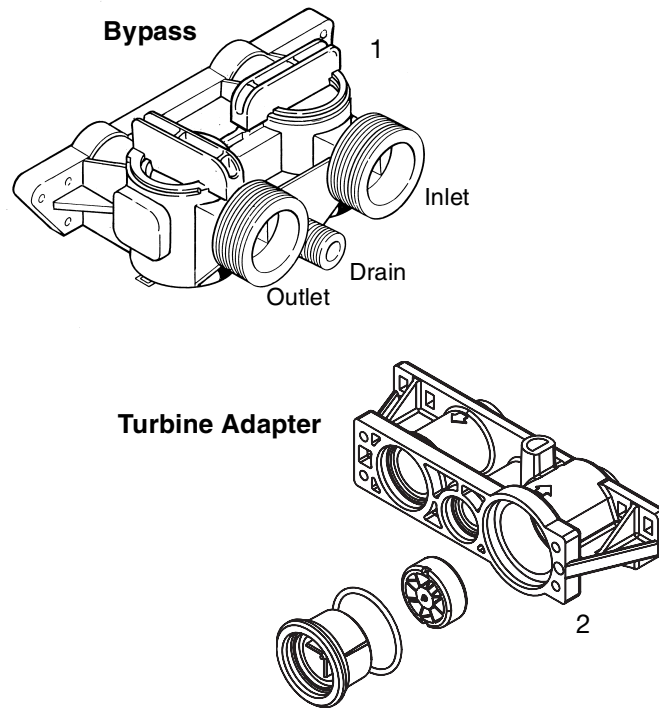

Item	Part No.	Description	Qty.
1	1040769	256 Bypass	1
*	1034301	Kit, 256 Rotor Replacement	2
*	1034302	Kit, 256 Rotor Seals (2), O-Rings (4), Clips (2)	
2	1032347	Assy, Adapter 1-inch Turbine included with 255A, P and L valves	1

*Not Shown

Manifold Kits

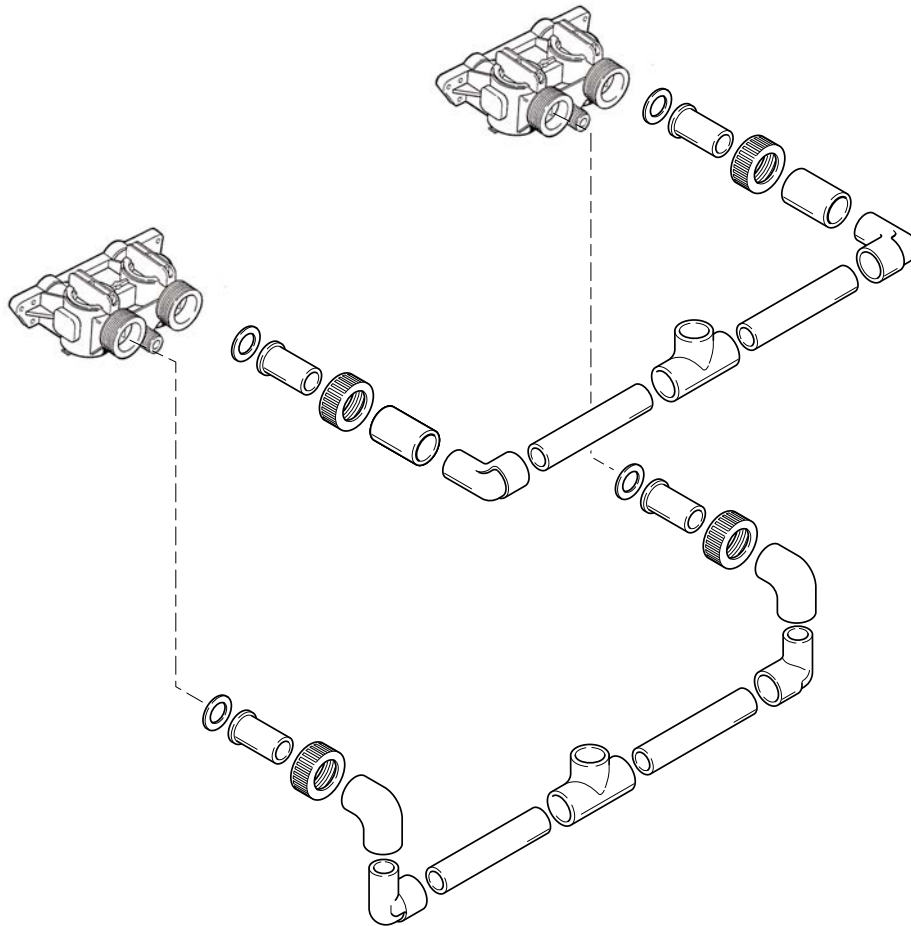

Part No.	Description	Qty.	Part No.	Description	Qty.
3019931	255 Manifold Kit, 1-in, PVC w/256 Bypass	1	3019932	764 Manifold Kit, 1-in PVC w/No Bypass	1
Kit Includes:			Kit Includes:		
	Pipe Fitting, Tee, 1-in	2		Pipe Fitting, Tee, 1-in	2
	Pipe Fitting, Elbow, Sch 40, 1-in, PVC	2		Pipe Fitting, Elbow, Sch 40, 1-in, PVC	2
	Pipe Fitting, Sch 40, 1-in, Str Elbow, PVC	4		Pipe Fitting, Sch 40, 1-in, Str Elbow, PVC	4
	Pipe Fitting, Sch 40, 1-in, Coupling,PVC	2		Pipe Fitting, Sch 40, 1-in, Coupling,PVC	2
	Gasket, 1.69 OD x 1.06 ID x 0.13 T, EP	4		Gasket, 1.69 OD x 1.06 ID x 0.13 T, EP	4
	Adapter Pipe, Soc Connector, 1-in, CPVC, Gray	4		Adapter Pipe, Soc Connector, 1-in, CPVC, Gray	4
	Pipe, 1-in, Sch 40 x 12.5 in. long, PVC, 255 Ry	4		Pipe, 1-in, Sch 40 x 12.5 in. long, PVC, 255 Ry	4
	Pipe-Tube Adapter Nut, 1.42 ID, Universal	4		Pipe-Tube Adapter Nut, 1.42 ID, Universal	4
	256 Bypass w/Install Kit, No Adapters. Single Pack	2			

Troubleshooting

764 Controller – Error Codes & 255 "L" with Check Salt Light

Problem	Possible Cause	Solution
ERR 1 is displayed.	Program settings have been corrupted.	Press any key and reprogram Level I settings.
ERR 3 is displayed.	Controller on tank 1 does not know the position of the camshaft. Camshaft should be rotating to find Home position.	Wait for two minutes for the controller to return to Home position. The hourglass should be flashing on the display indicating the motor is running.
	Camshaft on tank 1 is not turning during ERR 3 display.	Check that motor is connected. Verify that motor wire harness is connected to motor and controller module. Verify that optical sensor is connected and in place. Verify that motor gear has engaged cam gear. If everything is connected, try replacing in this order: 1. Wire Harness, Motor, Optical Sensor Assy 2. Controller
	Camshaft on tank 1 is turning more than five minutes to find Home position:	Verify that optical sensor is in place and connected to wire. Verify that camshaft is connected appropriately. Verify that no dirt or rubbish is clogging any of the cam slots. If motor continues to rotate indefinitely, replace the following components in this order: 1. Wire Harness, Motor, Optical Sensor Assy 2. Controller
	Regeneration starts but control shows Err3 before completing regeneration.	Verify that the correct valve is selected in the Logix controller.
ERR 4 is displayed.	If single tank system..	Verify system setting is programmed to 255 "L".
	Controller on tank 2 does not know the position of the camshaft. Camshaft should be rotating to find Home position.	Wait for two minutes for the controller to return to Home position. The hourglass should be flashing on the display indicating the motor is running.
	Camshaft on tank 2 is not turning during ERR 4 display.	Check that motor is connected. Verify that motor wire harness is connected to motor and controller module. Verify that optical sensor is connected and in place. Verify that motor gear has engaged cam gear. If everything is connected, try replacing in this order: 1. Wire Harness, Motor, Optical Sensor Assy 2. Controller
	Camshaft on tank 2 is turning more than five minutes to find Home position:	Verify that optical sensor is in place and connected to wire. Verify that camshaft is connected appropriately. Verify that no dirt or rubbish is clogging any of the cam slots. If motor continues to rotate indefinitely, replace the following components in this order: 1. Wire Harness, Motor, Optical Sensor Assy 2. Controller
Check Salt Light is displayed - Press the regen button to turn off the check salt light.	No regenerant draw or insufficient regenerant detected during regeneration.	Ensure salt/ regenerant is available. Check for regenerant draw. Inspect regenerant line for leaks

System Troubleshooting

Problem	Possible Cause	Solution
Regenerant tank overflow.	<ul style="list-style-type: none"> a. Uncontrolled refill flow rate. b. Air Leak in regenerant line to air check. c. Drain control clogged with resin or other debris. d. Aircheck ball on 255 valve prematurely seating due to air leak 	<ul style="list-style-type: none"> a. Remove refill flow control to clean ball and seat. b. Check all connections in regenerant line for leaks. c. Clean drain control. d. Check all connections in regenerant line for leaks.
Flowing or dripping water at drain or regenerant line after regeneration.	<ul style="list-style-type: none"> a. Valve stem return spring weak. b. Debris is preventing valve disc from closing. 	<ul style="list-style-type: none"> a. Replace spring. (Contact dealer). b. Remove debris.
Hard water leakage after regeneration.	<ul style="list-style-type: none"> a. Improper regeneration. b. Leaking of external bypass valve. c. O-Ring around riser pipe damaged. d. System capacity too low due to incorrect resin volume setting 	<ul style="list-style-type: none"> a. Repeat regeneration after making certain correct regenerant dosage was set. b. Replace bypass valve. (Contact dealer). c. Replace O-ring d. Reset control and program resin volume to correct setting
Control will not draw regenerant.	<ul style="list-style-type: none"> a. Low water pressure. b. Restricted drain line. c. Injector plugged. d. Injector defective. e. Valve disc 2 and/or 3 not closed. f. Air check valve prematurely closed. 	<ul style="list-style-type: none"> a. Make correct setting according to instructions. b. Remove restriction. c. Clean injector and screen. d. Replace injector and cap. (Contact dealer). e. Remove foreign matter from disc and check disc for closing by pushing in on stem. Replace if needed. (Contact dealer). f. Put control momentarily into brine refill. Replace or repair air check if needed. (Contact dealer).
Control will not regenerate automatically.	<ul style="list-style-type: none"> a. AC adapter or motor not connected. b. Defective motor. c. Fouled or defective turbine. d. Defective turbine cable. 	<ul style="list-style-type: none"> a. Connect power. b. Replace motor. (Contact dealer). c. Clean or replace turbine assembly. d. Replace turbine cable.
Control regenerates at wrong time of day.	<ul style="list-style-type: none"> a. Controller set incorrectly. 	<ul style="list-style-type: none"> a. Correct the time setting according to instructions.
Intermittent or irregular regenerant draw.	<ul style="list-style-type: none"> a. Low water pressure. b. Defective injector. 	<ul style="list-style-type: none"> a. Set pump to maintain 20 psi at conditioner. b. Replace injector (Contact dealer).
No conditioned water after regeneration.	<ul style="list-style-type: none"> a. No regenerant in regenerant tank. b. Injector plugged. c. Air check valve closes prematurely. 	<ul style="list-style-type: none"> a. Add regenerant to regenerant tank. b. Clean injector and screen. c. Quick cycle control into regenerant draw/slow rinse. Replace or repair air check if needed. (Contact dealer).
Backwashes or purges at excessively low or high rate.	<ul style="list-style-type: none"> a. Incorrect drain controller used. b. Foreign matter affecting valve operation. 	<ul style="list-style-type: none"> a. Replace with correct size controller (Contact dealer). b. Remove drain controller and clean ball and seat.
Run out of conditioned water between regenerations.	<ul style="list-style-type: none"> a. Improper regeneration. b. Incorrect resin volume setting 	<ul style="list-style-type: none"> a. Repeat regeneration, b. Reset control and program resin volume to correct setting
Control displays 1 - x (1 thru 4)	<ul style="list-style-type: none"> a. Control is in test mode 	<ul style="list-style-type: none"> a. Press control keys in order from left to right.

